



imagine colour efficiency for your business

MultiXpress CLX-8380ND

Introducing the all new MultiXpress CLX-8380ND, Samsung's latest A4 colour multi-function device. Its proven reliability, high quality colour output and innovative features outshine other devices in its class.

mono // colour // multi-function

www.samsung.com/uk/printer

SAMSUNG

Why Samsung?

With all the copiers and multi-function printers on the market, why choose Samsung? Samsung is a world renowned global company that regularly wins awards for reliability, design and innovative technology. It has the widest range of technologies and products, making it an expert in digital convergence. In the printing industry, Samsung is the fastest growing company, topping sales for many models.

Samsung has earned its reputation with award winning excellence, based on performance, eco-friendliness and design innovation and for providing businesses with network and security solutions. Samsung products are reliable and deliver a high monthly duty cycle, keeping business productivity steady. In addition, they are reliable with low toner failure, and produce high quality colour prints which are more durable and last a long time without fading.

Samsung has acquired global recognition and certification for being environmentally responsible, in terms of production, post-consumer recycling and creating pollution-free work environments.





imagine a highly productive, efficient and reliable colour ready MFD

The MultiXpress CLX-8380ND is the fastest A4 colour MFD in the market today. Its proven reliability, high quality colour output and innovative features outshine other MFDs in its class. The embedded administrative and accounting solutions make it the best choice for the business printing environment.

Now businesses do not have to sacrifice speed to gain multi-function features and colour printing. Samsung MultiXpress CLX-8380ND, A4 colour MFD, prints at incredible speeds of 38ppm. It is multi-talented and fast enough for even large corporate businesses.

Fast Copying

The MultiXpress CLX-8380ND produces 38ppm in black and white – and the same speed for colour, it performs nearly all the copy functions that are generally operated on A3 MFD.

Fast Printing

Printing colour or black and white document at 38ppm (simplex) and 33ppm (duplex) your jobs can be completed efficiently. Numerous standard print features help you to print document more easily and efficiently.

Vivid Colour Scanner & Network Scanning

The MultiXpress CLX-8380ND's enhanced scanning resolution (4800 x 4800dpi) and colour CCD method reproduce your document at its finest quality.

Fast Fax

The optional fax kit offers speed dial with up to 200 numbers and group dial up to 100 groups (up to 200 locations per group), duplex send and receive, fax-email and many other useful features. The duplex function enable the incoming fax be printed double-sided – saving your printing cost!

The Most Reliable Multi-Function Center

Maintains efficiency with Xpress reliability

Reliability is the word to describe MultiXpress CLX-8380ND. It offers all the functions that business expect from a DMFP – colour printing, digital copying, scanning and faxing – at the same time increasing business productivity with reliable performance, quality output and simple maintenance.

The most reliable performer

- **Wide Touch Screen/UI Design**
Samsung's exclusive 800 x 480 colour wide LCD touch screen and 3-dimensional UI design is very intuitive and easy to use – no manual or training required!

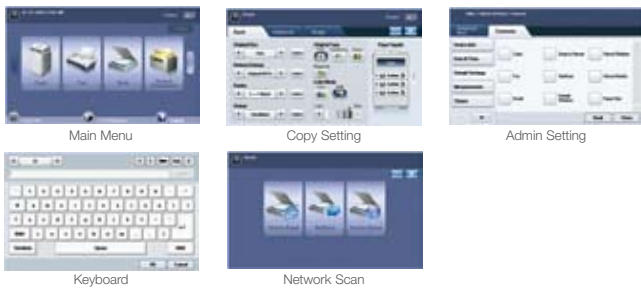

- **Paper Handling**
Adding optional paper trays to store up to 3240 sheets of paper at one time, reduce the frequency to refill paper.
- **Modular system**
The modular design make it easy to replace consumables, adding accessory and / or upgrade packages. For example, a finisher or memory can be easily slotted onto the main device.

- **Convenient Design**

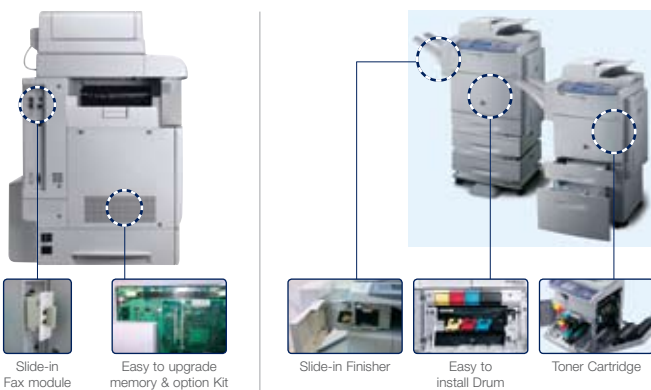

- **Paper Jam**
If and when a paper jam occurs the device indicates the problem area on the user display so you can simply, open the tray door to remove the jam.
- **Automatic Toner Ordering System (i-ATOS)**
This innovative Automatic Toner Ordering System makes it really easy and convenient for you to order supplies for your MFP. It automatically alerts the designated supplier by email, and it provides a direct link to the supplier's homepage for a quick order.



Offers control with Xpress customisation

Colour provides business professionalism to gain that winning edge. Samsung's MultiXpress CLX-8380ND provides high-speed colour printing and copying with customisable control to increase productivity and maintain economical running cost.

The most powerful solution center

- **Expanded Printing Capabilities with Hard Disk Solution**
The standard 80GB HDD ensures smooth print traffic in a busy office and print environment.



- **Scan to Anywhere**
The MultiXpress CLX-8380ND helps to distribute document efficiently by scanning directly to email, FTP, SMB or client.

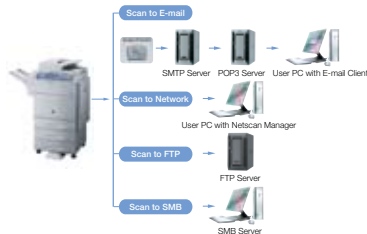

- **SyncThru™ Web Admin Service**
This service allows IT managers to easily manage and monitor all printers / MFPs on the network. The powerful feature permits job accounting, usage metering, authentication, storage management, remote driver installation and modification settings.

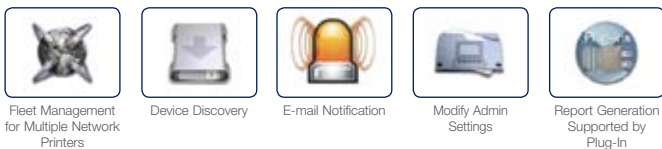

- **SyncThru™ Web Service**
It provides administrators with the ability to change network and individual printer settings, upgrade firmware and view network printer / MFP status.

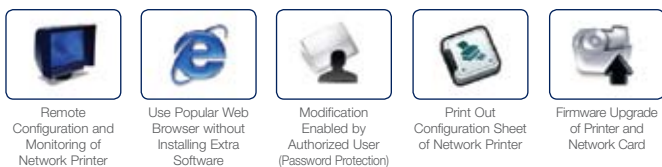

- **SmarThru™ Office**
In offices with complicated network with a variety of equipment, SmarThru's document management and editing features provide convenience and ease for users. Network scan is also provided as default.



- **SmarThru™ Workflow (Option)**
This option streamlines the document capture process route system enabling easy document management. This additional software is provided with the Samsung Network Scan Kit.

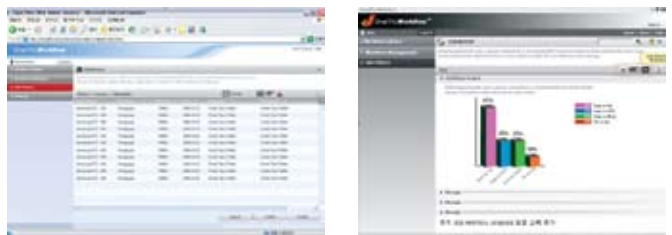

- **JScript™ Open Platform Printing**
JScript™ is a standardised, common platform that makes it possible to integrate solutions into an organisation's printers and MFPs and helps companies make the most of their printing investment. This embedded communication platform makes it simple to build on personalised solution packages that meet the needs of individual companies.

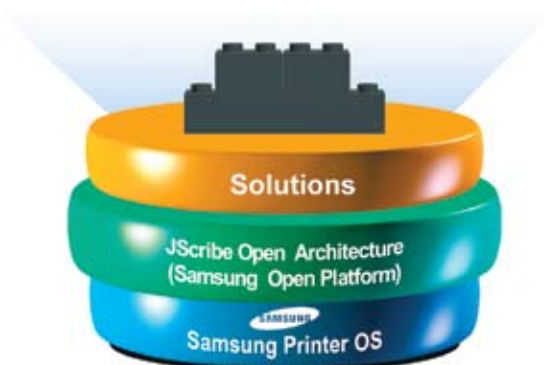

MultiXpress CLX-8380ND



MultiXpress CLX-8380ND



Specifications

- World's fastest A4 colour MFD capable of replacing or complimenting A3 MFD
- 38 pages per minute (A4 colour/mono)
- Network ready MFD
- 80GB HDD
- Built-in 100 sheets DADF, colour scan
- 7" wide colour touch screen UI
- Easy installable set & options
- Maximum 2720 sheet paper capacity
- Document management & workflow solutions
- Device administrative & job accounting solutions
- Optional JScribe® based solutions
- Machine life: 1million page
- 200k Maximum monthly duty cycle
- Click charge business model for customers

N: Network Ready / D: Duplex



38ppm
38ppm Colour & Mono Print & Copy Speed
Colour printing capability gives you the flexibility to add eye-catching colour to business documents.



4in1
Copy, Print, Scan and Fax
Four functions in one compact footprint for the ultimate in space-saving convenience and value for money.



2720
2720 Sheet Capacity Tray
Large paper capacity removes need to constantly add more paper and allows uninterrupted printing of large print jobs.



1200
1200dpi Print Resolution
Fine laser print resolution adds clarity and detail to printed documents for the most professional output.



10/100
Standard 10/100 Base TX Connectivity
Ethernet interface allows printer to be cabled directly into your office network.



200k
200k Page Duty Cycle
Printer built to handle the heaviest workloads for trouble-free operation month-in and month-out.

Configuration

Imagine gaining colour and efficiency with higher productivity. Samsung's MultiXpress CLX-8380ND printer provides businesses with a one-stop printing station that can print, scan and copy in high quality colour. With Samsung MultiXpress CLX-8380ND, it's not that hard to imagine.



Main Unit (520 sheets + MP 100 sheets)

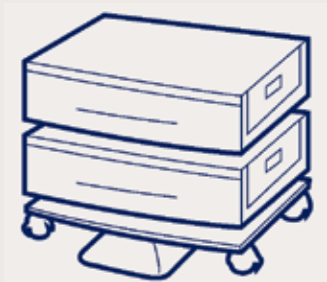

Option	<p>1 Finisher + HCF (High Capacity Feeder) 2100 sheets</p> 	<p>1 Finisher + Max. 2 SCF (Single Cassette Feeder) 520 sheets x 3 + Short Stand</p> 	<p>1 Finisher + Tall Stand</p> 
--------	--	---	--

PRINT

Speed (Mono) *	Simplex: up to 38ppm in A4 (40ppm in letter) / Duplex: up to 33ppm in A4 (35ppm in letter)
Speed (Colour) *	Simplex: up to 38ppm in A4 (40ppm in letter) / Duplex: up to 30ppm in A4 (31ppm in letter)
First print out time	Less than 13 seconds
Resolution	9600 x 600dpi effective output
Emulation	PCL5c, PCL6, PostScript3, PDF Direct V1.4
Duplex	Standard

COPY

Speed (Mono) **	Simplex: up to 38cpm in A4 (40cpm in letter) / Duplex: up to 33cpm in A4 (35cpm in letter)
Speed (Colour) **	Simplex: up to 38cpm in A4 (40cpm in letter) / Duplex: up to 30cpm in A4 (31cpm in letter)
Resolution	Up to 1200 x 1200dpi
First copy out time	Less than 13 seconds
Zoom rate	25%~400%
Multy copy	1~999
Duplex copy	Standard (1:2, 2:2, 2:1)
Copy features	N-up, ID card copy, auto fit, margin shift, book copy, covers, transparencies, auto suppression, booklet, clone, poster

SCAN

Compatibility	N/W TWAIN standard, WIA standard
Method	Colour CCDM
Resolution	600 x 600dpi (Optical) / 4,800 x 4,800dpi (Enhanced)
Scan to	E-mail, FTP, SMB, Client, USB (Direct scanning)

FAX (OPTIONAL)

Compatibility	ITU-T G3, Super G3
Modem speed	33.6Kbps
Resolution	Mono: 406 X 392dpi / Colour: 200 X 200dpi
Memory	HDD store
Auto dial	Speed dial: 200 locations
Fax feature	On hook dial, pause, auto redial, last number redial, PC fax

PAPER HANDLING

Input capacity and types	Standard: 520 sheet cassette tray (80g/m ²), 100 sheet MP tray (80g/m ²) / Max: 1660 sheets @ 80g/m ²
Output capacity and types	500 sheet face down (80g/m ² , 20lbs)
Media size	98mm x 148mm (3.85" x 5.83") ~ 216mm x 900mm (8.5" x 35.4") / Banner Size Printing: 216mm x 900mm
Media type	Plain paper, thick paper, thin paper, bond paper, colour paper, card stock, labels, transparency, envelope, preprinted, cotton, recycled paper, archive
ADF capacity	100 sheet DADF
ADF document size	Width: 145 ~ 216mm (5.7"~8.5") / Length: 145 ~ 356mm (5.7" ~ 14.0") for Single page scan, 145 ~ 400mm (5.7" ~ 15.7") for multi-pages scan

GENERAL

LCD	800 x 480 7" WVGA Colour Touch Screen
Memory / Storage	572MB (Max. 1088MB) / 80GB HDD
OS compatibility	Windows 2000 / XP (32/64bit) / 2003 (32/64bit) / Vista (32/64bit), Various Linux, Mac OS X 10.3~10.5
Interface	USB 2.0, USB Host 2.0, Ethernet 10/100 Base TX
Noise level	Printing 54dB / Copying 56dB / Standby 43dB
Duty cycle (Monthly)	100k sheets / month
Dimensions (W x D x H)	606.8mm x 575.0mm x 815.5 mm
Weight	Set: 71.5kg (with consumables) / Packaging: 93.6kg

SUPPLIES

Yield	Black toner cartridge (CLX-K8380A): average 20k standard pages Yellow (CLX-Y8380A) / Magenta (CLX-M8380A) / Cyan toner cartridge (CLX-C8380A): average 15k standard pages *** Imaging unit (CLX-R838XK/C/M/Y): average 30k pages Waste toner container (CLX-W8380A): average 48k pages
-------	---

OPTIONS

Options	Fax kit: SCX-FAX210 / Finisher: SCX-FIN10S / SmarThru™ Workflow: SCX-KIT11S / 512MB memory: CLP-MEM103 Staple cartridge: SCX-STP000 / Short stand: SCX-DSK10S / Tall stand: SCX-DSK10T / 520 sheet cassette tray: SCX-S6555A 2100 sheet HCF: SCX-HCF100 / FDI: SCX-KIT20F
---------	---

* Print speed will be affected by Operating system used, computing performance, application software, connecting method, media type, media size and job complexity.
** Copy Speed is based on Single Document Multiple Copy.
*** Declared continuous cartridge yield value in accordance with ISO/IEC 19798.
Specifications are subject to change without notification.

mono // colour // multi-function

Samsung Electronics (UK) Ltd

Registered Office:
Samsung House, 1000 Hillswood Drive,
Chertsey, Surrey KT16 0PS
Registered number: 3329545

www.samsung.com/uk/printer

In line with Samsung's commitment to continuous improvement this guide is subject to change without notice. E&OE.

